

BA-ECE 03 – Release 2015-11-25

ECE 03-0200-5E-MG



ID 155444



ID 155445



Warning

Present operating manual is a part of the product. Before installing and using you have to read all safety instructions, warnings and cautions carefully. Make sure that the warning labels are in readable conditions, replace missing or damaged ones.

Contact data for further information

Nicotra Gebhardt GmbH
Gebhardtstraße 19-25
74638 Waldenburg
Germany

Telephone: +49 (0)3765 / 101 - 0
Fax: +49 (0)7942 / 101 - 170
E-Mail: info@nicotra-gebhardt.com

Table of content





1	General Information	3
2	Overview	6
3	Features	6
3.1	Basic features of the devise	6
3.2	Inputs and Outputs	6
3.3	Fan Network – RS485 link	7
4	Installation	8
4.1	Ambient Operating Conditions	8
4.2	Mechanical Installation	9
4.3	Electrical Installation	10
4.3.1	Connection Overview	10
4.3.2	Connection Details	11
5	Working with the FC 200	15
5.1	Software	15
5.2	Commissioning	16
5.2.1	Quick Commissioning – fan driven by speed setting	16
5.2.2	Quick Commissioning – fan driven by closed loop control	16
6	Technical Data	17
7	Additional Hints	19
7.1	Manufacturing	19
7.2	Packing and Shipping	19
7.3	Service	19
8	Notes	20

1 General Information

Definition and Meanings

For all different safety instructions special symbols are used in this manual.

Follow all hints and warnings to avoid any injury or material damage. The user of the device is fully responsible.

	<p>Warnings „Warning“ indicates that death, severe personal injury or extensive property damage can result if proper precautions are not taken.</p>
	<p>Danger „Danger“ indicates an immediate risk of electric shock which will result in death, injury or serious damage if the applicable safety regulations are not followed</p>
	<p>Caution The symbol refers to a possible hazardous situation that could cause material or environmental damage.</p>
	<p>Recommendation and useful information and advices for an efficient operation free of malfunctions and faults.</p>

Qualified personal only



Only **qualified person(s)** must operate with the present device. This qualified personal must be familiar to these types of products and associated with danger and risks, authorized to install, mount, commission and use these types of product.

Designated use

Use this device only in the manner intended by the manufacturer, according to the manual and only in combination with the described products only.

Safety Instructions

All Warnings, Cautions and Hints shown in this document are provided for your safety and as a means of preventing damage to the product. This section lists Warnings, Cautions and Hints, which apply generally when handling the FC 200, classified as General, Transport & Storage, Commissioning, Operation, Service and Repair. Specific Warnings, Cautions and Hints that apply to certain specific chapters are listed at the beginning of the relevant chapters. Please read the information carefully, since it is provided for your own personal safety and it will also help prolong the service life of your product.

	<p>Warning This equipment controls potentially dangerous rotating mechanical parts. Noncompliance with Warnings or a miss to follow the instructions contained in this manual can result in loss of life, severe personal injury or serious damage to property.</p> <p>Only suitable qualified personal should work on this equipment, and only after becoming familiar with all safety notices, installation, operation and maintenance procedures contained in this manual.</p> <p>The successful and safe operation of this equipment is dependent upon its proper handling, installation, operation and maintenance. Children and the general public must be prevented from accessing or approaching the equipment!</p>
	<p>Information Keep these operating instructions within easy reach of the equipment and make them available to all users. Whenever measuring or testing has to be performed on live equipment suitable electronic tools should be used.</p> <p>Before installing and commissioning, please read these safety instructions and warnings carefully and all the warning labels attached to the equipment.</p>

Transport & Storage

	<p>Warning Correct transportation and storage, erection and mounting, as well as careful operation and maintenance are essential for proper and safe operation of the equipment.</p> <p>Protect the device against physical shocks and vibration during transport and storage. Also be sure to protect it against water (rainfall) and excessive temperatures.</p>
---	---

Commissioning and Operation



Warning

Use for intended purpose only. **The manual of the controlled fan regardless whether type of fan it is, is unconstrained by advices in this manual, especially in questions of safety.** Some parameter and settings lead to automatic restart of controlled fan after switch-on.

Service & Repair



Warning

Repairs and Service on the device may only be carried out or advised by **NICOTRA|Gebhardt**

Approbations



All devices of the FC 200 series are manufactured according

DIRECTIVE 2011/65/EU on the restriction of the use of certain hazardous substances in electrical and electronic equipment

under consideration of the following harmonized standard:

EN 50581:2012.

2 Overview

All devices of brand FC 200 (ECE 03-0200-5E-MG) are a stand-alone monitoring and control unit for up to 200 fans with RS485-based interface of different brands.

A clear and simple menu guide has been realised bilingual (English/German) and offers a very easy access to 2 separate, free configurable and individual operating closed loop cycles (Volume, Pressure, Temperature ...).

The devices are chose able as IP65-wallmounted solution or IP20-counter sunk design available with identic functions as well as customized OEM-solution in front design and software.

3 Features

3.1 Basic features of the devise

main supply	24V DC @ 100 mA
Usage/addressing	Standalone device for monitoring and control of up to 200 fans
Addressing	0(1) ... 99(100) according to applied field bus
Temperature	0°C ... 40°C operation (32°F ... 104°F) -20°C ... 70°C storage temperature (-4°F ... 158°F)
Display	Amber colored full graphic display
Access	easy access push encoder (IGR)
Time base	Real-time-clock

3.2 Inputs and Outputs



3 Digital Inputs (DIs)	<i>day-/night</i> <i>DI1</i> <i>DI2</i>	for day/night shift for external enable of group1 for external enable of group2 trigger +24V → DI
2 Digital Outputs (DOs)	<i>Error contact1</i> <i>Error contact2</i>	“error” for acknowledged, but still existing faults “new error” for new, unacknowledged faults programmable as low-active or high-active maximum contact load: 60V/500mA (peak AC / DC)

2 Analogue Outputs (AOs)	+10V	for sensor or potentiometer supply internal connected on 2 contacts (group 1 / 2) maximum load in total 20mA (peak AC / DC)
	+24V	for sensor supply internal connected on 4 contacts maximum load in total 100mA (peak AC / DC)
2 Analogue Inputs (AIs)	A/1	external sensor- or set value input of group1
	A/2	external sensor- or set value input of group2

3.3 Fan Network – RS485 link

Interface	<i>Line 1</i> <i>Line 2</i> 2 identical lines - fieldbus - programmable <i>ebmpapst – Modbus, ebmBUS</i> <i>Nicotra Gebhardt – Modbus, GBus</i> <i>Ziehl Abegg – Modbus</i>
Hardware	Transceiver acc. RS485 specification Half duplex 1/8 Load up to 256 nodes (subscriber limited to 100 per line) max. 400m line length
Data	Baud rate: 9600, 19200, 38400, 57600 Parity: none, even, odd Stop bits: 1, 2
Features	set values speed enable maximum speed minimum speed fault (depending on chosen fan brand)

4 Installation

	<p>Warning Installation of the FC 200 by qualified personal only. This qualified personal must be familiar to these types of products and associated with danger and risks, authorized to install, mount, commission and use these types of product.</p> <p>Some parameters can cause a start of connected and powered fans, without any further confirmation required (scheduler, day/night shift ...).</p>
	<p>The device is fed by safety extra-low voltage (SELV) and matches to protection class III.</p>

4.1 Ambient Operating Conditions

	<p>Devices of the FC 200 series are designed and manufactured for indoor installation.</p> <p>Wall mounted variations have with closed lid IP 65 (environmental protection class). Devices in counter-sunk style rated as IP20, additional sealed, transparent lid available on request</p>
--	---

Shock

	<p>Warning Do not drop the device or expose to sudden shock.</p> <p>Do not use the device in an area where it is likely to be exposed to constant vibration higher than 2,5 mm*s⁻¹.</p>
---	---

Temperature

	<p>Warning Do not use device outside temperature range of 0°C ... 40°C (32°F ... 104°F)</p>
---	--

Electromagnetic Radiation

	<p>Warning Do not use the device near sources of electromagnetic radiation.</p>
---	--

4.2 Mechanical Installation

Wall-Mounted Style

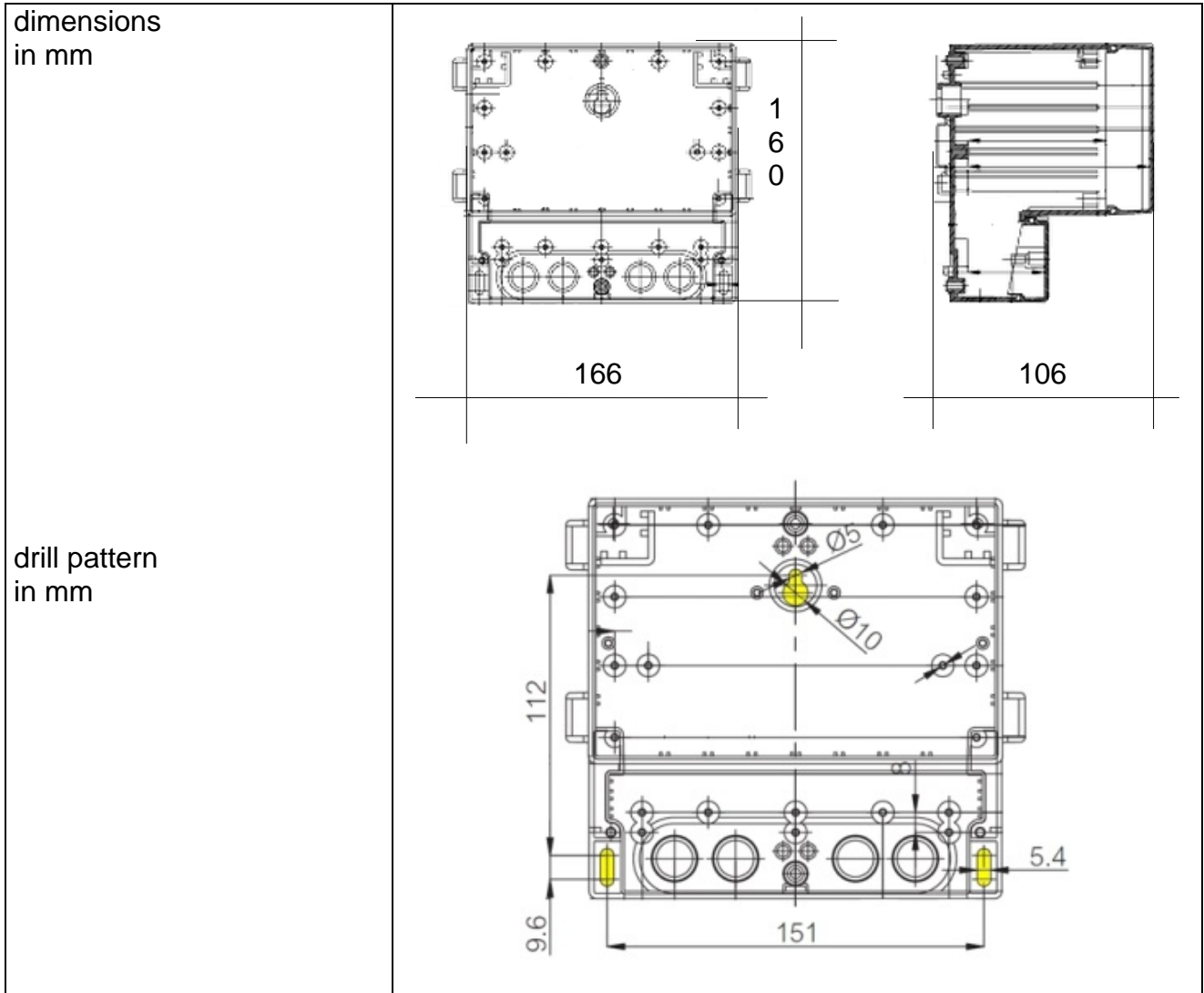

Counter-Sunk Style

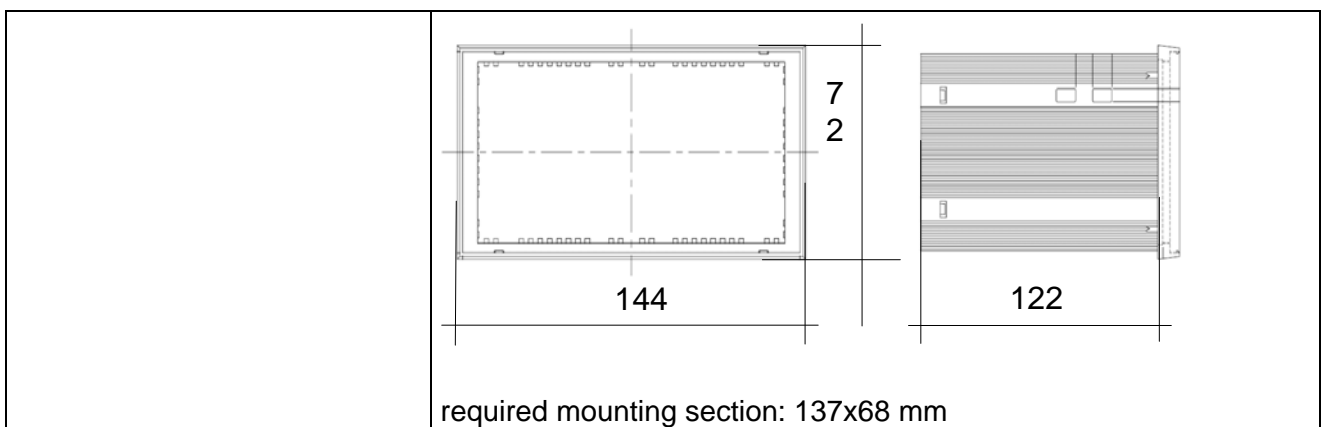

4.3 Electrical Installation

4.3.1 Connection Overview

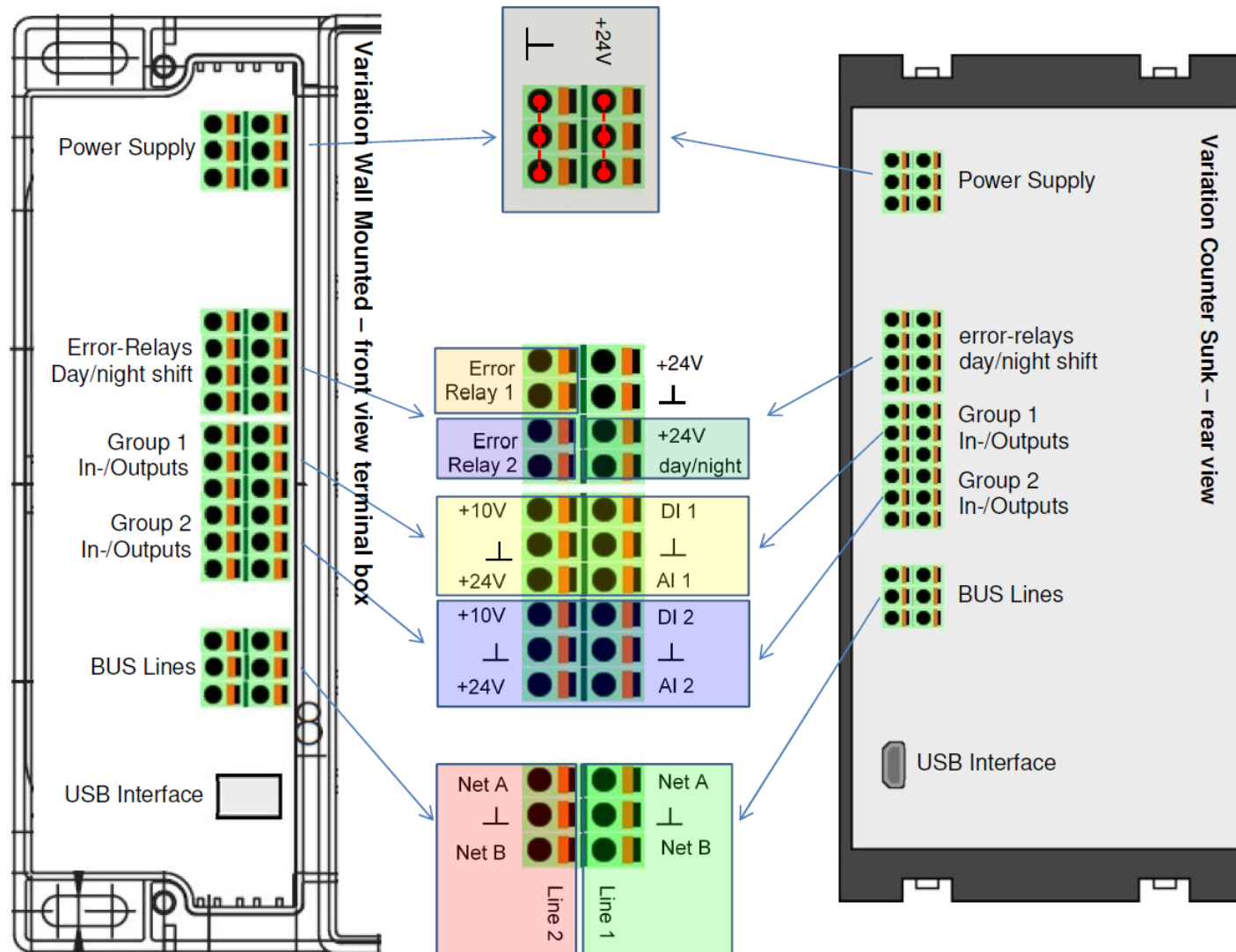

Description Connection

	<p>The terminal assignment of both design variations Wall-mounted and Counter sunk is identically.</p>
---	--

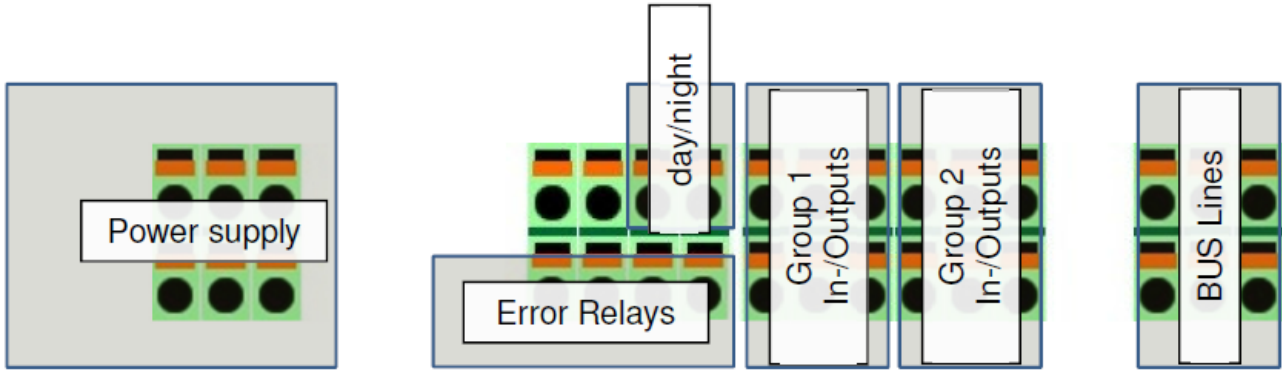

4.3.2 Connection Details

Power Supply

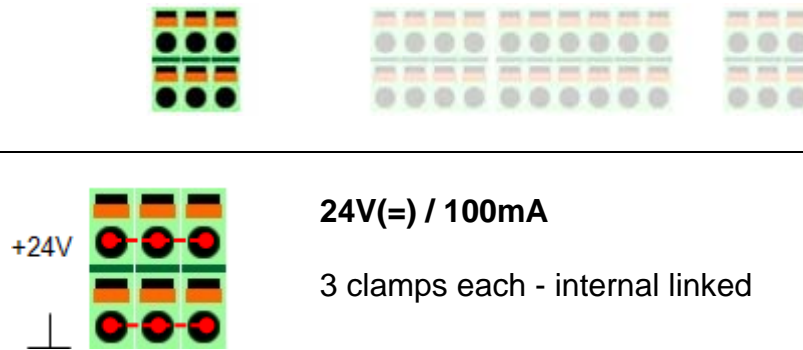

Error Relays

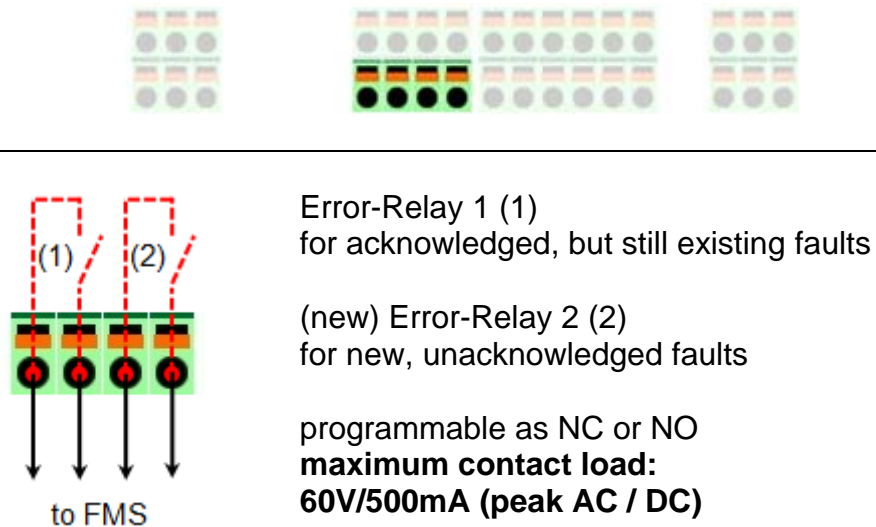

Day/Night

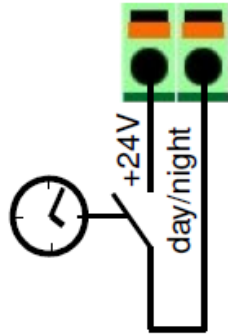
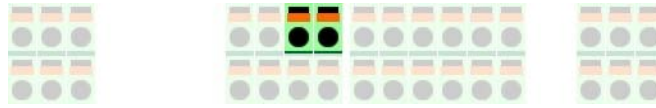

Day/Night Shift

Tripping +24V → day/night

Group1
In-/Outputs

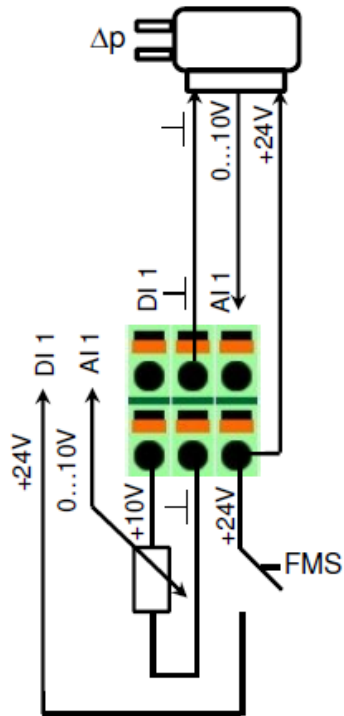
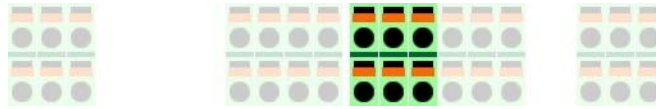

Group 1

DI1 (tripping +24V → DI1)
External enable of control group 1

AI1 (0 ... 10V)
analogue measure- or setpoint input

+10V (Power Supply for Sensor / Potentiometer)
maximum load in total (with Group 2)
20mA (peak AC / DC)

+24V (Power Supply Sensor)
maximum load in total (with Group 2)
100mA (peak AC / DC)

Group2 In-/Outputs

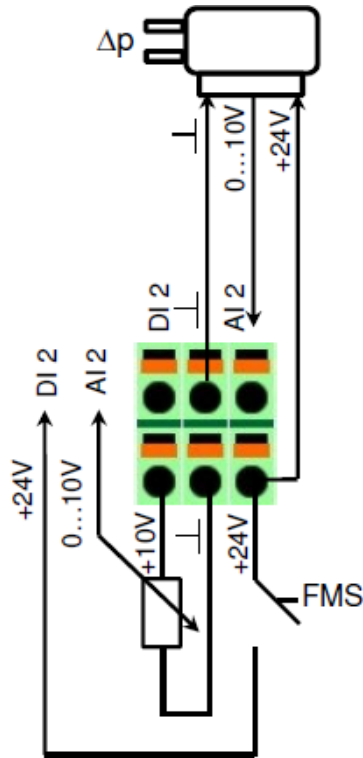
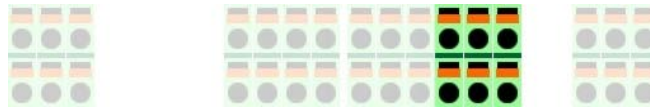

Group 2

DI1 (tripping +24V → DI1)
External enable of control group 2

AI1 (0 ... 10V)
analogue measure- or set point input

+10V (Power Supply for Sensor / Potentiometer)
**maximum load in total (with Group 1)
20mA (peak AC / DC)**

+24V (Power Supply Sensor)
**maximum load in total (with Group 1)
100mA (peak AC / DC)**

BUS Lines

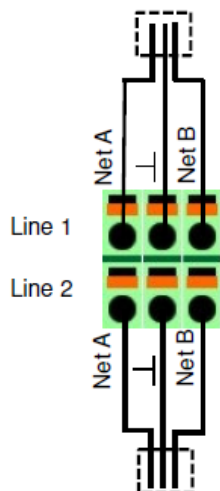

Line 1

Connect up to 100 subscriber with RS485
Interface

Line 2

Connect up to 100 subscriber with RS485
Interface

WARNING!

**Handling of unused PINs according to
specification of applied EC-fan supplier!**

4.3.2 Connection Example

Group 1 – closed loop control pressure

3 fans at line 1

Sensor signal Δp as 0...10V and 24V(=) power supply

Extern enable of closed loop controller by FMS

Group 2 – speed control by potentiometer

2 fans at line 2

Potentiometer for speed setting by 0...10V

Internal enable of control

General connection

day/night - shift – external timer

Utilization error/new error by costumer FMS with external 24V (~) supply

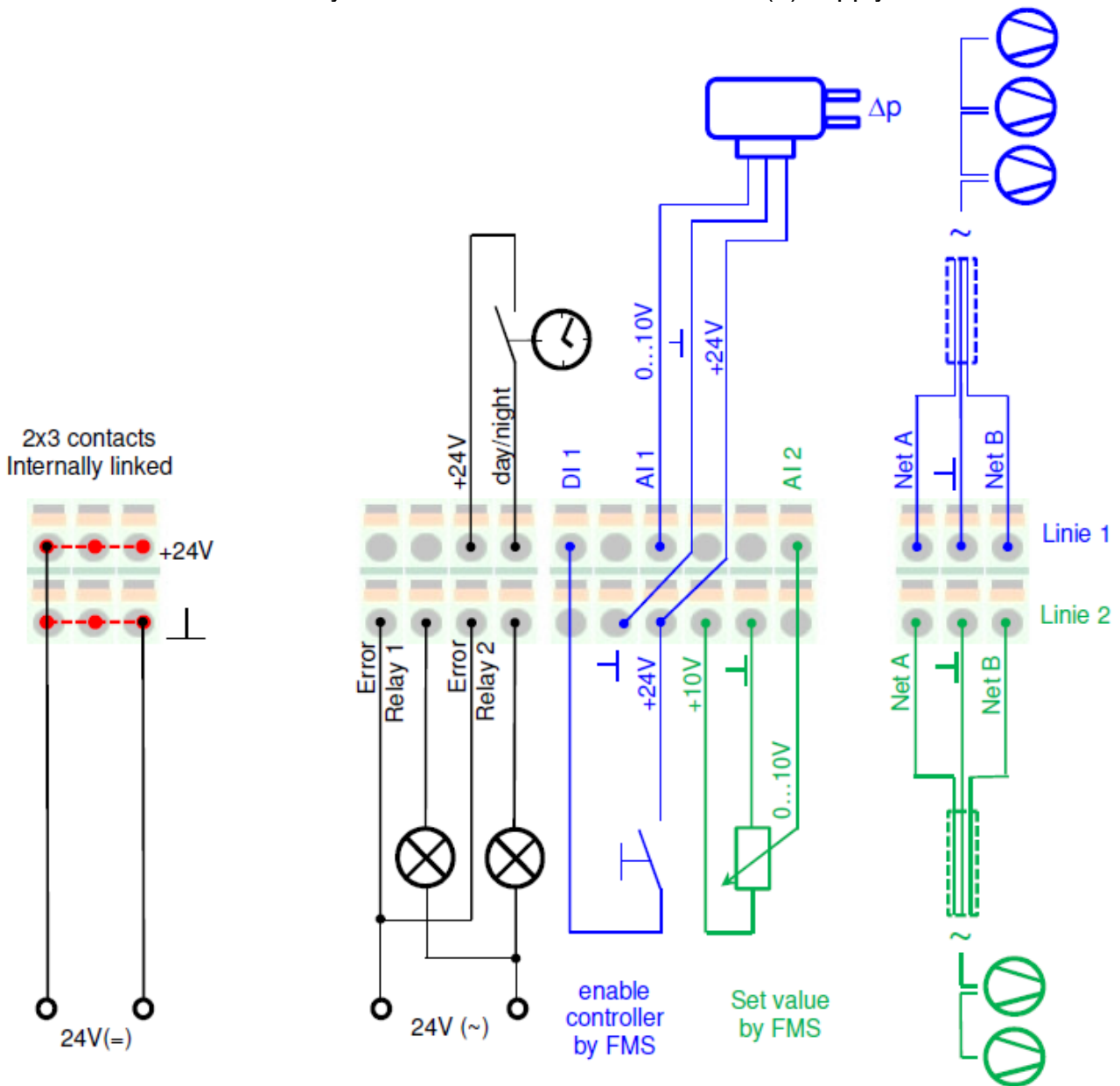

5 Working with the FC 200

5.1 Software

Display	
Scan Line	Network scan to find all connected devices with the chosen protocol
Single Monitor	Cyclic scan of single device and monitoring of requested data
Single Control	Control of a single addressable device with feedback
Group Control	Control of all fans assigned to one of 20 speed control groups
Broadcast	Control / Parameterizing of all connected devices without feedback (broadcast)
Group Building	up to 20 groups (free definition) for simple speed control and up to 2 groups for closed loop control mode
Internal PI-Controllers (2)	two separate closed loop control circuits free programmable as temperature, velocity, pressure and % fixed assigned sensor signal inputs (1/2) and digital inputs (1/2) to each closed loop control group (1/2)
Error Output	as error indication signal and free configurable signal outputs (high/low active) maximum 60V – 500mA Error 1 → red for acknowledged, but still existing faults Error 2 → red alternating for new, unacknowledged faults
Operating Levels	3 operating levels (Monitor / Operator / Administrator)
Timer	Programmable Scheduler for set-point shift of single fans and assigned groups

5.2 Commissioning

5.2.1 Quick Commissioning – fan driven **by speed setting**

required: Connection Power supply (24V) / Bus (NetA/NetB)

Mainmenu	
Sublevel 1	
Sublevel 2	
Sublevel 3	
1. „Login“ as Administrator	default password „0000“
2. „Database“	
used Bus Line (1/2) „Config Line“	choose relevant Bustyp
„Install Fan“	
„Scan Line“	Found devices will be installed automatically – correct fan addressing required!
3. „Configuration“	choose – Single / Line / Group / All max. speed checked or set correctly
4. „Control“	choose – Single / Line / Group / All
„Speed Day“	set day speed in %
„Start Fan“	Start Control

5.2.2 Quick Commissioning – fan driven **by closed loop control**

required: Connection Power supply (24V) / Bus (NetA/NetB) / Sensor AI (0...10V)

1. „Login“ as Administrator	default password „0000“
2. „Database“	
used Bus line (1/2) „Config Line“	choose relevant Bustyp
„Install Fan“	
„Scan Line“	Found devices will be installed automatically – correct fan addressing required!
„Assign group“	assign (fan) group (1 ...10) for closed loop control 0 = none group
3. „Configuration“	choose – Single / Line / Group / All max. speed checked or set correctly
4. „Controller“	choose – Single / Line / Group / All
„Config Controller“	choose Controller 1 or Controller 2 (acc. connection of sensor to AI1 or AI2)
„Group“	assign under #2 defined fan group to Controller if needed adapt further controller settings
„Control Controller“	choose Controller 1 or Controller 2
„Set Day“	Set Control value in %
„Start Controller“	Start Controller with “Day-setting”

6 Technical Data

Connection

Power Supply	24V (=)
Current Consumption	maximum 100mA rating according load of 24V (=) i.e. by sensors
Connection plugs <i>Serie</i>	Cage Clamps Phoenix FMCD 1,5/ x-ST-3,5
<i>Wire cross section</i>	min. 0,2mm ² / max. 1,5mm ² (solid and stranded) min. 0,25mm ² / max. 1,5mm ² (stranded with ferrule <u>without</u> plastic collar) min. 0,25mm ² / max. 0,75mm ² (stranded with ferrule <u>with</u> plastic collar)
<i>Wire cross section (AWG)</i>	min. AWG/kcmil 24 / max. AWG/kcmil 16

Housing

Variation	<i>Wall-Mounted</i> with lid Fibox Cardmaster PC 1716-I3TT	<i>Counter-Sunk</i> OKW NEG TYP A 144x72
Dimensions (LxBxH)	166 x 160 x 100mm	144 x 72 x 129mm
Weight	appr. 700g	appr. 500g
Protection Class (DIN EN 60529)	IP65	IP20
Material	Polycarbonate (UL 94-5V)	Noryl (UL 94 V-0)
Protection Class (electrical) (DIN EN 61140)	III (Safety Extra Low Voltage) No Protective Earth	III (Safety Extra Low Voltage) No Protective Earth

Ambient Operating Conditions

usage	indoor application
Temperature	0°C ... 40°C (32 ... 104°F) - Operating -20°C ... 70°C (-4°F ... 158°F) - Storage
relative humidity	0 ... 90%, non-condensing

IN- and OUTPUTs

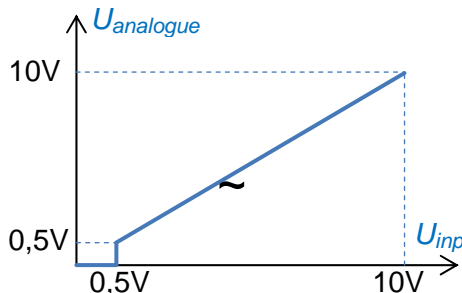
<p>Digital Inputs DI (<i>day/night; enable group</i>)</p>	<p>+24V → DI (Voltage) 10mA (minimum current source capacity) 4 kV (isolating voltage against internal circuit)</p>
<p>Analogue Inputs AI (<i>Sensor values-, Speed setting</i>)</p>	<p>0 ... 0.5 ... 10V (=) from 0.5V linear</p> <p>40 kΩ (internal resistance)</p> <p>3,75 kV (isolating voltage against internal circuit)</p> 
<p>Digital Outputs DO (<i>Error relays</i>)</p>	<p>as low-active or high-active programmable 60V (max. Voltage as peak AC / DC) 500mA (max. Current as peak AC / DC) 1,5 kV (max. Current as peak AC / DC)</p>
<p>Analogue Outputs AO <i>Sensor Power Supply</i></p>	<p>+10V (=) 20mA (max. Current as peak AC / DC)</p> <p>+24V (=) 100mA (max. Current as peak AC / DC) min 1kV (isolating voltage across DC/DC converter)</p>

Fan Network

Hardware	RS485
Maximum Subscriber	200 at 2 Lines (100 / Line)
Maximum line length	400m (per Line)
Baud rate	according type of subscriber
cable	(recommended) Cat. 5
isolating voltage against internal circuit	2,5 kV (overvoltage class 2)

7 Additional Hints

7.1 Manufacturing

All devices of the FC 200 series are manufactured according

DIRECTIVE 2011/65/EU on the restriction of the use of certain hazardous substances in electrical and electronic equipment

7.2 Packing and Shipping

The shipping is in fitting individual packing.

For export the FC 200 is categorized to the following HS code

85176200

Machines for the reception, conversion and transmission or regeneration of voice, images or other data, incl. switching and routing apparatus (excl. telephone sets, telephones for cellular networks or for other wireless networks)

All claims for damage must be reported immediately.

7.3 Service

Technical queries about the FC 200 under:

Nicotra Gebhardt GmbH
Gebhardtstraße 19-25
74638 Waldenburg
Germany

Telephoneon: +49 (0)3765 / 101 - 0
Fax: +49 (0)7942 / 101 - 170
E-Mail: info@nicotra-gebhardt.com

8 Notes